

DESCRIPTION:

The 313 Super Bright series is conventional 4.8mm flangeless LED lamps utilizing higher intensity materials to achieve superior performance.

The semi-conductor materials used are:

GaAlAs for (313HR3C/HR3D)

GaP for (313VGC/VGD, 313YGUC/YGUD)

GaAsP/GaP for (313VYC/VYD)

AlGaInP for (313RS1C/RS1D, 313UY1C/UY1D)

ABSOLUTE MAXIMUM RATINGS: (Ta=25°C)

Reverse Voltage	5 Volt
Reverse Current (Vr =5V)	100µA
Operating Temperature Range	-40°C To 85°C
Storage Temperature Range	-40°C To 100°C
Lead Soldering Temperature (1.6mm (1/16)From Body)	260°C For 5 Seconds

NOTES : 1. All dimensions are in millimeters.

2. Lead spacing is measured where the leads emerge from the package.

3. Protuded resin under flange is 1.5 mm (0.059") Max.

PACKAGE DIMENSIONS

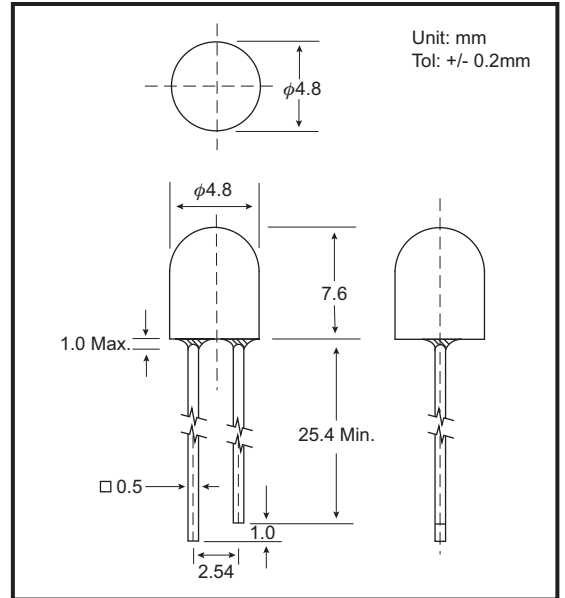

PART NO. SELECTION AND APPLICATION INFORMATION (RATINGS AT 25°C AMBIENT)

Part No.	Emitted Color	Lens Color	Peak Wavelength λp (nm)	Vf (v)		Rec. If (mA).	Iv (mcd)		View Angle 2θ1/2(Deg)
				Min	Max		Min	Typ.	
GB-313HR3D	Super Red	Red Diffused	660	1.7	2.6	10-20	23.0	37.0	45
GB-313RS1D	Super Red	Red Diffused	635	1.7	2.6	10-20	250.0	300.0	45
GB-313VGD	Super Green	Green Diffused	565	1.7	2.6	10-20	31.0	51.0	45
GB-313YGUD	Super Green	Green Diffused	565	1.7	2.6	10-20	40.0	65.0	45
GB-313VYD	Super Yellow	Yellow Diffused	585	1.7	2.6	10-20	11.0	18.0	45
GB-313UY1D	Super Yellow	Yellow Diffused	590	1.7	2.6	10-20	90.0	145.0	45
GB-313HR3C	Super Red	Water Clear	660	1.7	2.6	10-20	81.0	130.0	30
GB-313RS1C	Super Red	Water Clear	635	1.7	2.6	10-20	800.0	1000.0	30
GB-313VGC	Super Green	Water Clear	565	1.7	2.6	10-20	110.0	180.0	30
GB-313YGUC	Super Green	Water Clear	565	1.7	2.6	10-20	140.0	230.0	30
GB-313VYC	Super Yellow	Water Clear	585	1.7	2.6	10-20	40.0	63.0	30
GB-313UY1C	Super Yellow	Water Clear	590	1.7	2.6	10-20	310.0	500.0	30

TESTING CONDITION FOR EACH PARAMETER :

PARAMETER:	SYMBOL	UNIT	TEST CONDITION
REVERSE VOLTAGE	Vr	VOLT	Vr = 5.0 Volt
REVERSE CURRENT	Ir	µA	If = 20mA
FORWARD VOLTAGE	Vf	VOLT	If = 20mA
LUMINOUS INTENSITY	Iv	MCD	If = 20mA
VIEWING ANGLE	2θ1/2	DEGREE	
RECOMMENDED OPERATING CURRENT	If (Rec)	mA	

