

DESCRIPTION:

The 883 Super Bright series is solid state square type lamps encapsulated in 8mm diameter package, and is most suitable for moving sign display.

The semi-conductor materials used are:

GaAlAs for (883HR3C)

GaP for (883VGC/VGD/VGT)

GaAsP/GaP for (883VYC/VYD/YT)

AlGaInP for (883RS1C, 883UO1D)

ABSOLUTE MAXIMUM RATINGS: (Ta=25°C)

Reverse Voltage	5 Volt
Reverse Current (Vr =5V)	100μA
Operating Temperature Range	-40°C To 85°C
Storage Temperature Range	-40°C To 100°C
Lead Soldering Temperature (1.6mm (1/16)From Body)	260°C For 5 Seconds

NOTES : 1. All dimensions are in millimeters.

2. Lead spacing is measured where the leads emerge from the package.

3. Protuded resin under flange is 1.5 mm (0.059") Max.

PACKAGE DIMENSIONS

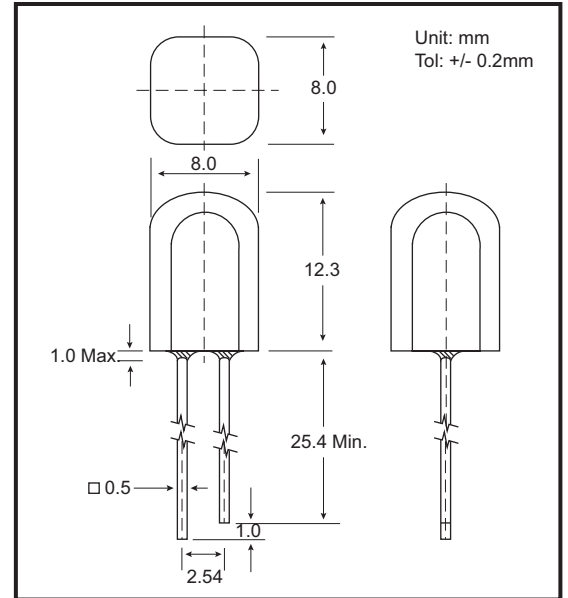

PART NO. SELECTION AND APPLICATION INFORMATION (RATINGS AT 25°C AMBIENT)

Part No.	Emitted Color	Lens Color	Peak Wavelength λp (nm)	Vf (v)		Rec. If (mA).	Iv (mcd)		View Angle 2θ1/2(Deg)
				Min	Max		Min	Typ.	
GB-883VGD	Super Green	Green Diffused	565	1.7	2.6	10-20	2.5	10.0	54
GB-883VYD	Super Yellow	Yellow Diffused	585	1.7	2.6	10-20	2.5	10.0	54
GB-883UO1D	Amber	Orange Diffused	620	1.7	2.6	10-20	200.0	400.0	54
GB-883VGT	Super Green	Green Trans.	565	1.7	2.6	10-20	10.0	25.0	36
GB-883VYT	Super Yellow	Yellow Trans.	585	1.7	2.6	10-20	10.0	25.0	36
GB-883HR3C	Super Red	Water Clear	660	1.7	2.6	10-20	300.0	500.0	36
GB-883RS1C	Super Red	Water Clear	635	1.7	2.6	10-20	600.0	800.0	36
GB-883VGC	Super Green	Water Clear	565	1.7	2.6	10-20	10.0	25.0	36
GB-883VYC	Super Yellow	Water Clear	585	1.7	2.6	10-20	10.0	25.0	36

TESTING CONDITION FOR EACH PARAMETER :

PARAMETER:	SYMBOL	UNIT	TEST CONDITION
REVERSE VOLTAGE	Vr	VOLT	Vr = 5.0 Volt
REVERSE CURRENT	Ir	μA	If = 20mA
FORWARD VOLTAGE	Vf	VOLT	If = 20mA
LUMINOUS INTENSITY	Iv	MCD	If = 20mA
VIEWING ANGLE	2θ1/2	DEGREE	
RECOMMENDED OPERATING CURRENT	If (Rec)	mA	

